



Sign Lighting World
720-242-900
Sales@signLightingWorld.com
www.SignLightingWorld.com



S-1300-CW65

CE RoHS



◆ Features

- ✧ Constant Current Technology, 20pcs per series
- ✧ Back radiator for cooling
- ✧ Injection molding process, water proof: IP 67
- ✧ High efficiency chip, high brightness and reliability
- ✧ Energy saving, environment friendly
- ✧ Long life span

◆ Applications

- ✧ Commercial standing lighting
- ✧ Light box lighting

◆ Dimensions

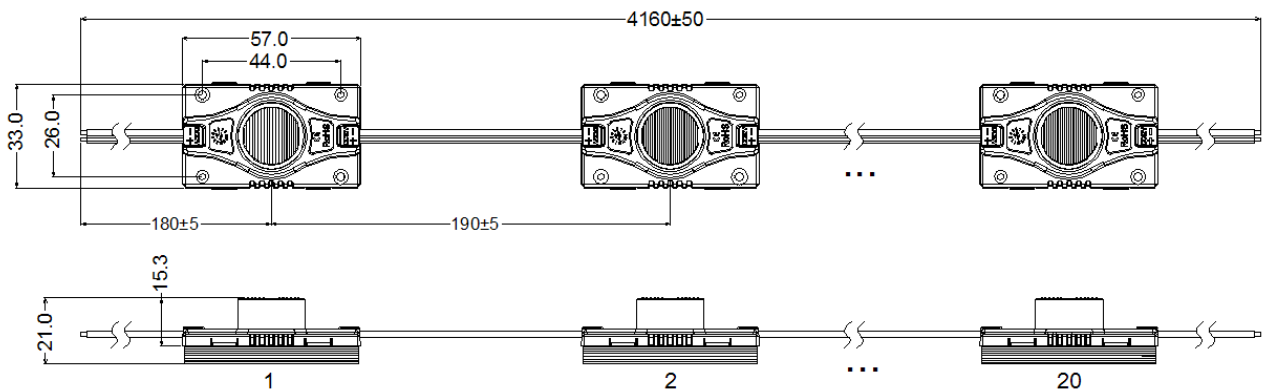

Unit: mm

Note: The cable between modules can be customized within a certain range.

◆ Technical parameters

Part No.	Color	Wave Length or CCT	Operating Voltage	Rated Power per module	Beam Angle	Lm Flux per module	IP Rate
S-1300-CW65	Pure white	6000-8000K	DC12V	3 W	15°×55°	220lm	IP67

◆ Distribution curve

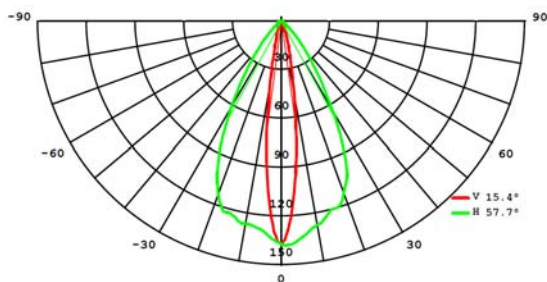

CE RoHS



◆ Application Guide



◆ Attentions

1. Maximum number of modules per chain is 20pcs from power supplier to single end.
2. The parameters may change as the type of material of lighting boxes or channel letters.
3. The LED module including its components can't be mechanical stressed.
4. Please ensure that the power supply has adequate power to operate the total load.
5. Only professionals can tear down, install or maintain LED modules.
6. All of box materials used for installation have to meet anti-flame rules and related so on.
7. Power supply should be short circuit and overloading protection, and total power should be less than rated power 80% of that power.
8. Working Temperature: -25~55℃.